

JUNIOR BILLET PLANTER



The Gessner Sugar Cane Billet Planter is the culmination of meticulous research and development and state-of-the-art engineering, designed to provide its operator with an efficient, effective and durable billet planting solution. Provide your new crop with the best chance to thrive with a Gessner Billet Planter.

- Heavy duty 100x100x9m main frame.
- Fixed front wheels with manual depth control.
- 750kg billet hopper capacity and 165kg fertiliser bin capacity.
- Cat 2 or Cat 2-3N three point linkage
- 725mm wide robust chain drive conveyor with steel flights. Ground driven conveyor.
- Plough board assemblies come complete with adjustable 14" covering discs and a heavy duty press wheel.
- Delivered in containers full assembled.

General Assembly	9901-200
Description	Single Row Billet Planter
Overall Weight (empty)	1,260kg
Overall Width (with Fertilizer Biz)	2536mm
Overall Width (without Fertilizer Biz)	2287mm
Overall Length	2750mm
Overall Height	2378mm
Billet Hopper Capacity	750KG
Fertilizer Bin Capacity (Urea)	165KG
Elevator	CA550 (2") Pitch Conveyor Chain Drive
Main Framez	100 x 100 x 9 RHS
Plough Assembly	250mm (10") Standard
Covering Discs	Adjustable 14" Diameter
Press Wheel	Spring Loaded - 18 X 8.50-8 (Max Pressure - 22 Psi)
Three Point Linkage	Cat 2 Or Cat 2-3n
Drive Chains	ASA60 3/4" Pitch
Wheel Hubs & Axles	Manufactured By Gessner - 6 Stud
Depth/Drive Wheels	Adjustable - 7.50 X 16 X 10 Ply
Average Planting Rate	6 Tonnes / Hectare - 300mm To 350mm Billets

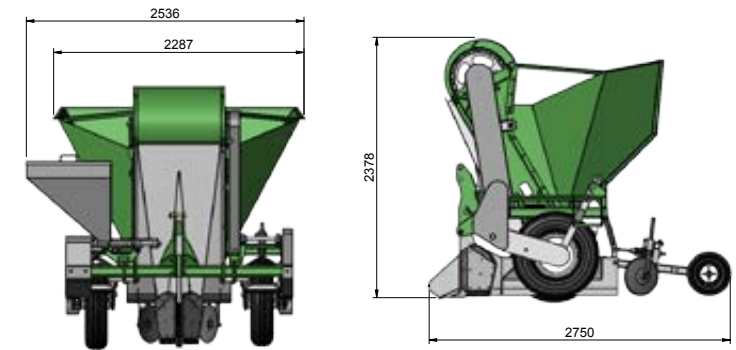

SINGLE ROW BILLET PLANTER

FEATURES

- Fixed front wheels with manual depth control.
- Rear castor wheels fitted with hydraulic position locks.
- Heavy duty swivel tow hitch.
- 10mm rubber conveyor belt with bolted steel flights.
- Hydraulic controlled gate to regulate billet flow.
- Over head spray bars.
- Plough board assemblies come complete with two covering discs and a heavy duty press wheel.
- Heavy duty 30" twin disc openers are attached to the plough board.
- Stainless steel fertiliser bins.
- Optional liquid tanks for chemical application.



General assembly	9900-670
Overall weight (empty)	6,250kg
Overall width	3,459mm
Overall length	5,050mm
Overall height	3,350mm
Height to rear of hopper	2,550mm
Billet hopper capacity	3,000kg - 3,500kg
Fertilizer bin capacity	2 x 650kg stainless bins (1,300kg total)
Liquid fertilizer capacity (optional)	2 x 500l tanks (1,000l total)
Elevator	1200mm rubber belt c/w steel flights
Optional elevator	Ca550 (2") pitch conveyor chain drive - steel flights
Main frame	150 x 100 x 9 rhs
Plough assembly	200mm - 450mm
Disc opener assembly (optional)	30" x 6mm
Covering discs	Adjustable - 14" diameter
Press wheel	Spring loaded - 18 x 8.50-8
Three point linkage	Cat 2-3n - cat 3
Drive chains	16b-1 1" pitch roller chain
Wheel hubs & axles - front	Manufactured by gessner - 6 stud
Wheel hubs & axles - rear	80-6 4,000kg triple lip seals
Front depth wheels	7.50 x 16 hd16 l/truck tyre & 6 stud wheel
Rear wheels	13.0/65-18 bkt aw702 tyre & 6 stud wheel
Average planting rate	6.0 tonnes / hectare - 300mm billets

